



Score (*Europe*) Limited

Intelligent Valve Management™

www.score-europe.com



Essential Valve Maintenance



Approvals held within the Score group of companies

Score Valve Maintenance Services

Throughout our proud 35 year history, Score (Europe) Limited have been the market leaders in the valve industry providing a 'Total Valve Management' package to our clients including critical after-market maintenance services.

These services provide a proactive low cost solution to extend the life of the plant, maximise production and mitigate the potential of equipment failure or high cost unplanned outages.



STOP THE PROBLEM BEFORE IT STARTS!!



Preventative Maintenance

Millions are spent every year on replacing or repairing valves/actuators which have been neglected following installation.

In order to maximise the field service life of these products, it is essential that all valves and actuators are serviced on a regular basis.

Detailed below are some examples of typical valve maintenance carried out by our team of multi-skilled field service technicians which will undoubtedly improve valve performance and increase service life.

- Valve Site Surveys/Non-Invasive Maintenance
- Outage Planning & Spares Procurement
- Preventative Maintenance Programs
- Flushing & Lubrication
- Seat Integrity Testing
- Corrosion Prevention

Reactive Maintenance

We understand that preventative maintenance may not always be possible. It is therefore critical to our clients that we can react in the event of an emergency in order to maintain valve integrity.

- Emergency Valve/Actuator Repairs
- Sealant Injection & Lubrication
- Bespoke Engineering Solutions
- In-line Thru Valve Leak Detection
- Valve/Actuator Torque Testing



Sealant Injection & Lubrication Solutions

Score have been working in partnership with world leading valve lube sealant provider Val-Tex for over 15 years in order to offer market leading valve maintenance solutions.

As the official authorised UK agent for Val-Tex, Score will assess your requirement and select the best possible solution to your problem. Val-Tex offer a wide range of valve lube sealants and equipment to cover every scenario, whether it be reducing operating torques or improving seat leakage.



Lube Sealants

- Biodegradable multi-purpose valve flush for cleaning out hardened sealants & service media build ups
- Biodegradable multi-purpose valve lube sealants to cover a range of service mediums, pressures & temperatures. Val-Tex 75, 85, 700, 750
- Emergency lube sealants containing FTFE chips for high seat leakage scenarios. Val-Tex 700 +FTFE

Lubrication Equipment

- HP Manual hand operated Lube Sealant Gun - 1400
- HP Manual Foot operated Pump - QS1800A Viper
- HP Air/Hydraulic Pump - QS 2000A
- HP Electrical/Hydraulic Pump - QS 2200A
- Various injection fittings, adaptors, body bleeds & pressure release tools

Training

Score offer hands-on training on various maintenance techniques including sealant injection and lubrication in our training centre of excellence. Training includes:

- Inspection & survey techniques
- Typical valve failures
- Recognising when valves require sealant/lubrication
- Injection equipment
- The injection process
- Bespoke training courses to suit client requirements

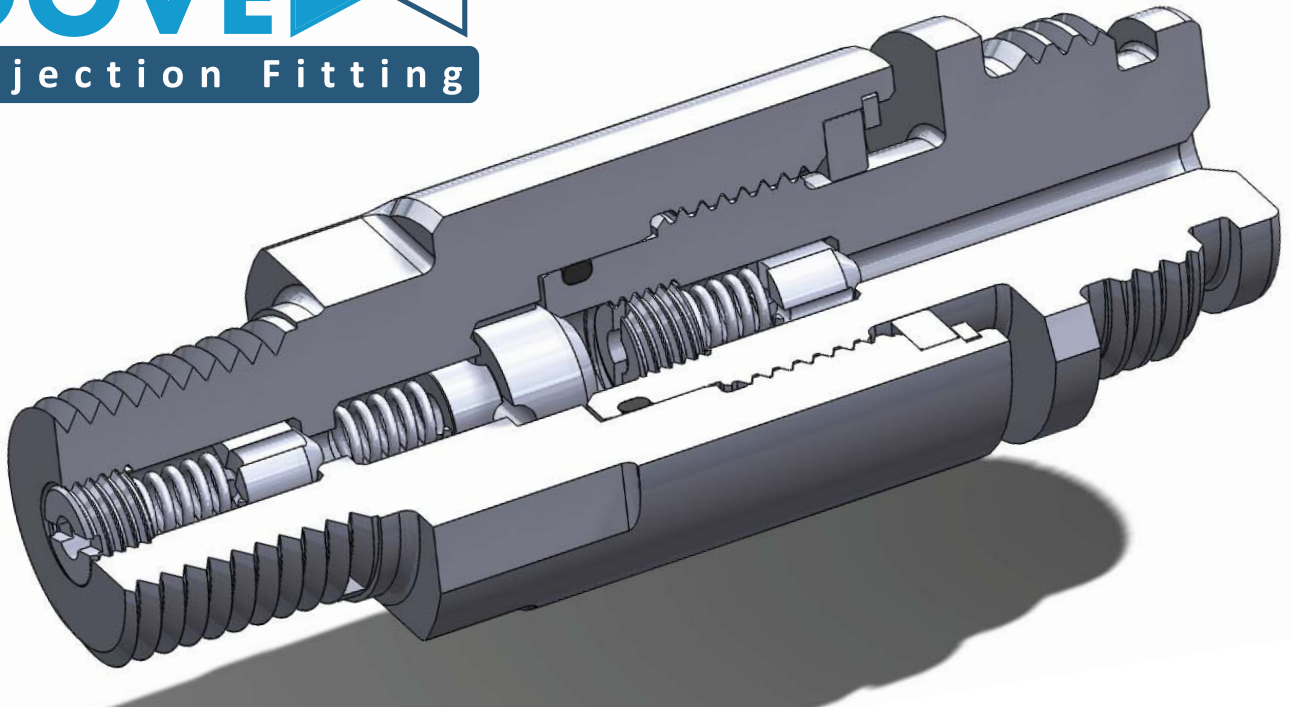

Dove II - One of the safest injection fittings on the market

Dove II is a two part injection fitting designed and manufactured by Hycrome (Europe) Limited, part of Score Group plc. Its features include:

- Manufactured in virtually any material or connection size, depending on requirements
- Two part injection fitting – components cannot be accidentally unscrewed
- Inline design, allowing for installation in areas of limited space
- The specially designed Mech-Check mechanism allows mechanical isolation between the two main body parts, retaining a constant seal throughout operation
- Rated to 10,000 psi
- Burst & fire test qualifications API 6FA and API 6FD 1st Edition

Score (Europe) Limited
Glenugie Engineering Works
Peterhead, Aberdeenshire
Scotland
AB42 0YX
Tel: +44 (0) 1779 480 000



Score (Europe) Limited
Intelligent Valve Management™
www.score-europe.com

Success Commitment Ownership Respect Excellence